



**National Committee on
Uniform Traffic Control Devices**

17200 West Bell Road No.1135 * Surprise, Ariz. 85374
Telephone (623) 214-2403 * e-mail: ncutcd@aol.com

NOTE: This is a recommendation to FHWA on changes to the MUTCD by the National Committee on Uniform Traffic Control Devices (NCUTCD). This recommendation is not a revision to the MUTCD and does not constitute official standards, guidance, or options. No proposed revision to the MUTCD is effective unless and until approved by FHWA through an Interim Approval or through the Federal rulemaking process.

TTC Agenda item 7 June 2014

**National Committee on Uniform Traffic Control Devices
TTC TC**

TECHNICAL COMMITTEE: NCUTCD Temporary Traffic Control Technical Committee

DATE OF ACTION: 6-26-14

TASK FORCE: David Church (chair), Hicks, Leonard, Lohman, Flaherty, Stroth, Ullman, Edmonds, Putman

TTC TC APPROVAL DATE: 6-26-14

TRANSMITTAL TO SPONSORS DATE:

TOPIC: Figure 6H-28. Sidewalk Detour or Diversion (TA-28)

AFFECTED PORTIONS OF MUTCD: 2009 Edition – Figure 6H-28

DISCUSSION:

Revisions to TA-28 were approved by Council in June 2013. Sponsor comments indicated that several of the modifications were not clearly labeled. TTC agrees and made the noted clarifications on the drawing. These clarifications were approved by Council at the June 2014 meeting.

Because the revised figure includes the new elements of ramp and temporary walking surface, the notes are revised to address these elements.

38 Both the clarifications on the figure and the supporting notes were approved by Council June 28,
39 2014.

40
41 **RECOMMENDATION:**
42 Add the clarifications to the figure as noted below.

43
44 **RECOMMENDED WORDING:**

45
46 **Note: this language is from the 2009 Edition, Section**
47
48 **The change in only in the figure for Sidewalk Diversions.**

49
50 **This is the Figure in the 2009 Edition:**

Figure 6H-28. Sidewalk Detour or Diversion (TA-28)

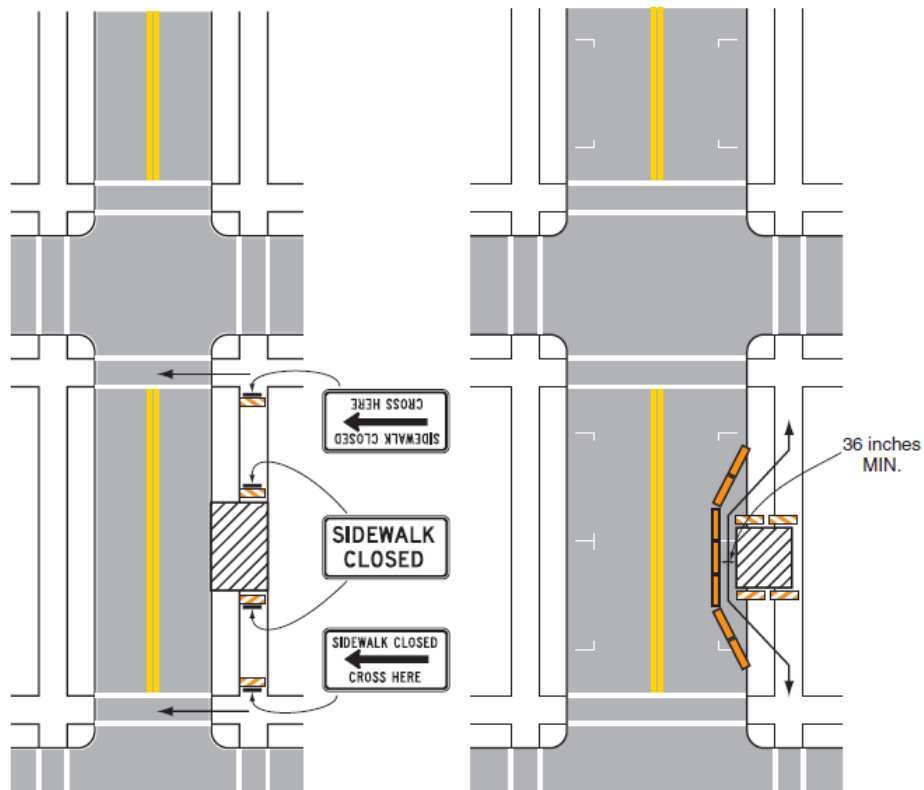

51
52
53
54
55

Approved by Council in June 2013

Clarification approved by Council June 2014

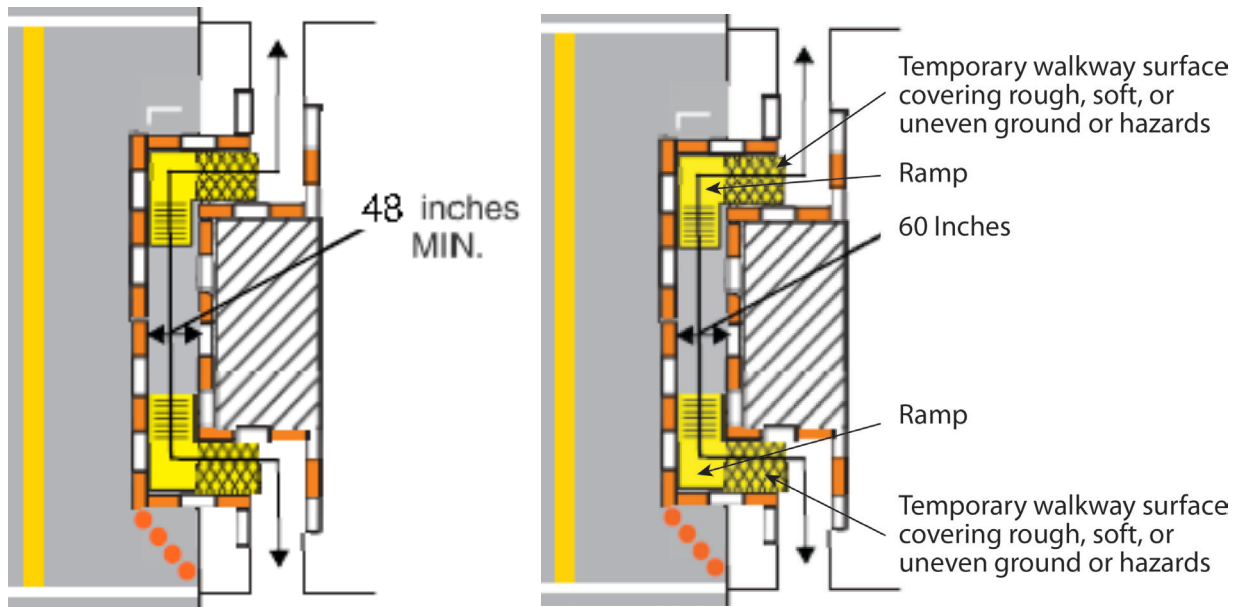

Note: this language is from the 2009 Edition, Figure 6H -28 (TA-28)

Standard:

1. When existing pedestrian facilities are disrupted, closed, or relocated in a TTC zone, the temporary facilities shall be detectable and include accessibility features consistent with the features present in the existing pedestrian facility. A pedestrian channelizing device, Figure 6F.xx, that is detectable by a person with a visual disability traveling with the aid of a long cane shall be placed across the full width of the closed sidewalk.
2. When used, temporary ramps shall provide a 12:1 (8%) slope or flatter with a slip-resistant surface. ~~comply with Americans with Disabilities Act.~~ Ramp landing area shall provide a 48 x 48 inch minimum area with a 2% or flatter cross-slope.
3. When used, Longitudinal Channelizing Devices used for temporary pedestrian routes shall comply with 6F.71.

Guidance:

4. The surface of an alternate pathway should meet the requirements of Americans with Disabilities Act.
5. The protective requirements of a TTC situation have priority in determining the need for temporary traffic barriers and their use in this situation should be based on engineering judgment.
6. Audible information devices should be considered where midblock closings and changed crosswalk areas cause inadequate communication to be provided to pedestrians who have visual disabilities.

83 **Standard:**

84 **7. Temporary traffic barriers, if used, shall comply with the provisions of Section**
85 **6F.85.**

86
87 Option:

88 8. Street lighting may be considered.

89 9. Only the TTC devices related to pedestrians are shown. Other devices, such as lane
90 closure signing or ROAD NARROWS signs, may be used to control vehicular traffic.

91 10. For nighttime closures, Type A Flashing warning lights may be used on barricades that
92 support signs and close sidewalks.

93 11. Type C Steady-Burn or Type D 360-degree Steady-Burn warning lights may be used on
94 channelizing devices separating the temporary sidewalks from vehicular traffic flow.

95 12. Signs, such as KEEP RIGHT (LEFT), may be placed along a temporary sidewalk to
96 guide or direct pedestrians.

97 **Width of the alternate pedestrian route may be 48 inches with a passing area of 60 inches**
98 **every 200 feet.**