



**National Committee on
Uniform Traffic Control Devices**

17200 West Bell Road No.1135 * Surprise, Ariz. 85374
Telephone (623) 214-2403 * e-mail: ncutcd@aol.com

TTC Agenda item XII January 2013

**National Committee on Uniform Traffic Control Devices
TTC TC**

TECHNICAL COMMITTEE: NCUTCD Temporary Traffic Control Technical Committee

DATE OF ACTION: 1-10-13

TASK FORCE: David Church (chair), Tim Stroth, Tim Cox

RWSTC APPROVAL DATE: 1-10-13

TRANSMITTAL TO SPONSORS DATE: 3-11-13

TTC TC APPROVAL FOLLOWING SPONSOR COMMENTS: 6-27-13

COUNCIL APPROVAL DATE: 6-28-13

TOPIC: Figure 6H-28 – Typical Application 28 Sidewalk Detour or Diversion

AFFECTED PORTIONS OF MUTCD: Notes for Figure 6H-28, Figure 6H-28

DISCUSSION:

Figure 6H-28 and the accompanying notes describe 2 common situations that occur when construction closes a sidewalk: a Sidewalk Detour and a Sidewalk Diversion. The Figure depicts typical traffic control to guide pedestrians around work that occurs on and closes the sidewalk. As with all of the TAs in Chapter 6H, these figures are to be used as a starting point to deal with the need for alternate pathways for pedestrians when sidewalks are closed.

A practitioner recently contacted TTC to note a discrepancy between the Figure for Sidewalk Diversion and other sections in Part 6. Review of the practitioners comment showed several areas where this figure is not compliant with other sections of Part 6. The areas that are not compliant include:

- Lack of an accessible, detectable barricade between the pathway and the work space

- 35 • Use of a type 3 barricade to close the sidewalk which does not provide the detectability that
36 Section 6.
- 37 • Use of the symbol for Longitudinal Channelizing Device to separate the alternate pathway from
38 vehicular traffic without a note requiring that the LDC meet the detectability requirements of
39 Section 6.
- 40 • Width of the alternate pathway is noted at 36 inches while Section 6. Requires 48 inch
41 minimum
- 42 • Lack of notice to practitioners that a ramp is required when elevation changes by more than ½
43 inch.

44 **RECOMMENDATION:**

45
46 Modify Figure 6H-28 Sidewalk Diversion to include longitudinal channelizing devices on both sides of the
47 alternate pathway that are detectable to users of long canes and that have upper and lower rails as
48 noted in 6.; adjust the width to read 48 inches minimum and depict ramps between the curb and the
49 alternate walking surface. Modify the Notes to TA-28 to bring them into compliance with the 2009
50 Edition of the MUTCD and to support the modifications to the Figure. Include in the notes clarification
51 of the use of temporary traffic barriers.

52
53 **RECOMMENDED WORDING:**

54
55 **Note: Proposed changes to the MUTCD are shown in underline red and removed text are**
56 **shown in ~~strikethrough red~~.**

57
58
59

60 **Notes for Figure 6H-28—Typical Application 28**
61 **Sidewalk Detour or Diversion**

62
63

Standard:

- 64 ~~1. When crosswalks or other pedestrian facilities are closed or relocated, temporary~~
65 ~~facilities shall be detectable and shall include accessibility features consistent with~~
66 ~~the features present in the existing pedestrian facility.~~
- 67 1. When existing pedestrian facilities are disrupted, closed, or relocated in a TTC zone,
68 the temporary facilities shall be detectable and include accessibility features
69 consistent with the features present in the existing pedestrian facility. A pedestrian
70 channelizing device, Figure 6F.xx, that is detectable by a person with a visual
71 disability traveling with the aid of a long cane shall be placed across the full width of
72 the closed sidewalk.
- 73 2. When used, temporary ramps shall comply with Americans with Disabilities Act.
- 74 3. When used, Longitudinal Channelizing Devices used for temporary pedestrian routes
75 shall comply with 6F.71 63.

76

77 *Guidance:*

78 ~~2. Where high speeds are anticipated, a temporary traffic barrier and, if necessary, a crash~~
79 ~~cushion should be used to separate the temporary sidewalks from vehicular traffic.~~

80 ~~4. The surface of an alternate pathway should meet the requirements of Americans with~~
81 ~~Disabilities Act.~~

82 ~~5. The protective requirements of a TTC situation have priority in determining the need for~~
83 ~~temporary traffic barriers and their use in this situation should be based on engineering~~
84 ~~judgment.~~

85 ~~36. Audible information devices should be considered where midblock closings and changed~~
86 ~~crosswalk areas cause inadequate communication to be provided to pedestrians who~~
87 ~~have visual disabilities.~~

88

89 **Standard:**

90 **7. Temporary traffic barriers, if used, shall comply with the provisions of Section**
91 **6F.85.**

92

93 *Option:*

94 ~~48.~~ Street lighting may be considered.

95 ~~59.~~ Only the TTC devices related to pedestrians are shown. Other devices, such as lane
96 closure signing or ROAD NARROWS signs, may be used to control vehicular traffic.

97 ~~610.~~ For nighttime closures, Type A Flashing warning lights may be used on barricades that
98 support signs and close sidewalks.

99 ~~711.~~ Type C Steady-Burn or Type D 360-degree Steady-Burn warning lights may be used
100 on channelizing devices separating the temporary sidewalks from vehicular traffic flow.

101 ~~812.~~ Signs, such as KEEP RIGHT (LEFT), may be placed along a temporary sidewalk to
102 guide or direct pedestrians.

103 **13. Width of the alternate pedestrian route may be 48 inches with a passing area of 60**
104 **inches every 200 feet.**

105

106 Modify the Figure in TA-28 as shown below:

107

108 Figure in MUTCD 2009 Edition

Proposed Figure for TA-28

109

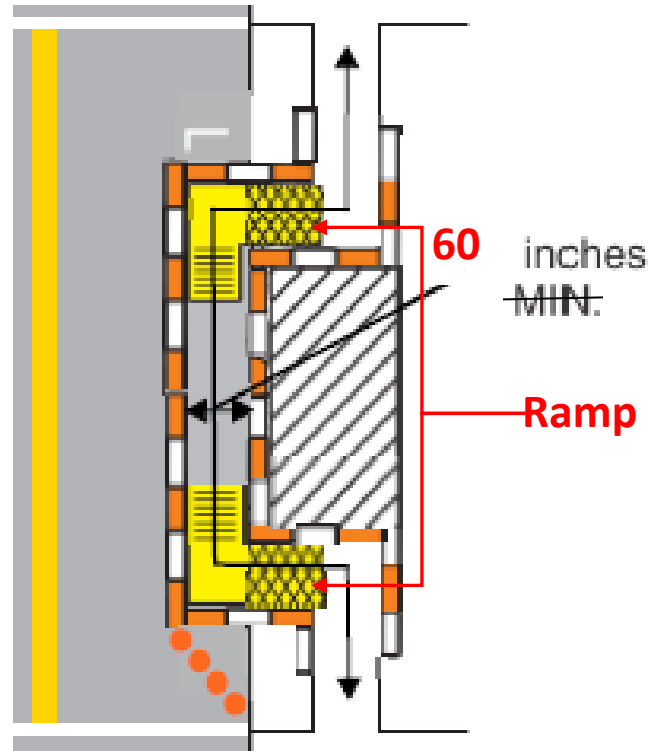
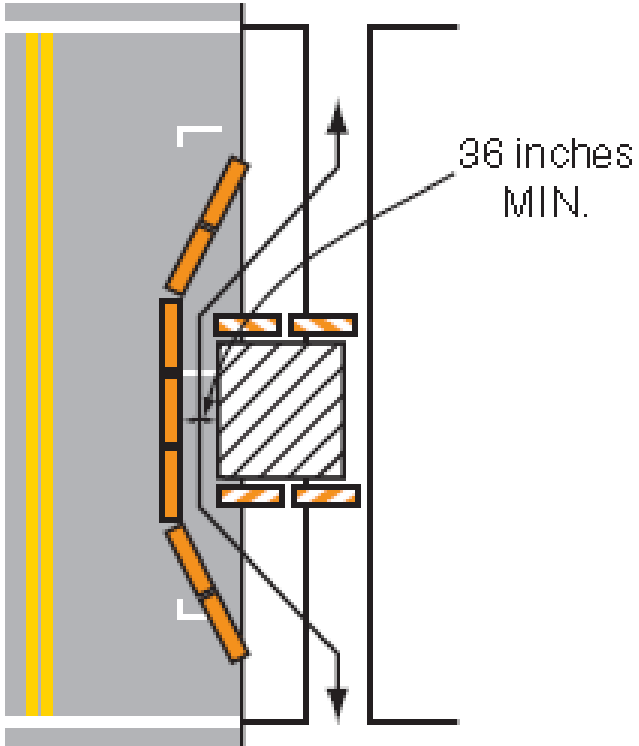

111

112 [Note – add symbols in 6H-2 for ramp and pedestrian channelizing device]